







<p>DO.XB.7100000 DO.XC.7100000 DO.YB.7100000 DO.YC.7100000</p>	<p>The Traxon Dot XL RGB is an extra bright clear or diffused dot, with 6 or 9 LEDs per dot casing. The dots are constructed on a flexible cable with a customizable pitch containing up to 32 dots (9-LED) or 47 dots (6-LED). The dots are single dot controllable by DMX or e:pix (DVI capable), and are connected per string using the Dot XL Pixel Distributor. The Pixel Distributors can be daisy chained to form large installations.</p>	 
		 
		  

PRODUCT SPECIFICATIONS

- **Model:** DO.XB.7100000 (Dot XL-6, 40PXL, 300mm pitch)
DO.XC.7100000 (Dot XL-9, 32PXL, 300mm pitch)
DO.YB.7100000 (Dot XL-6 with diffuser dome, 40PXL, 300mm pitch)¹
DO.YC.7100000 (Dot XL-9 with diffuser dome, 32PXL, 300mm pitch)¹
- **Light Source:** 6 or 9 High intensity Nichia SMD LEDs per dot
- **Color Range:** 16.7 Million additive RGB colors
- **Color Resolution:** 3 x 14-bit (Gamma correction)
- **Beam Angle:** 120° (clear cover), 170° (diffuser dome)
- **Luminous Flux²:** DO.XB.7100000/DO.XC.7100000: 42.7 lm / 65.9 lm
DO.YB.7100000/DO.YC.7100000: 28.2 lm / 43.7 lm¹
- **Efficacy²:** DO.XB.7100000/DO.XC.7100000: 17.1 lm/W / 18.8 lm/W
DO.YB.7100000/DO.YC.7100000: 11.3 lm/W / 12.5 lm/W¹
- **Cover Lens:** Clear or diffuser dome¹ (PC)
- **LED Pitch:** Manufacture to order; dot-to-dot pitch: 150mm minimum
- **Housing:** Die cast aluminium with PC cover
- **Adjustment Options:** Flexible cable
- **Size:** Ø66mm x 15.6mm / Ø2.6" x 0.6" (Dot) Ø66mm x 36mm / Ø2.6" x 1.4" (Dot with diffuser dome)
- **Weight:** 80g (Dot); 670g (Pixel Distributor)
- **Regulatory Listing & Safety Approval:** CE, cETLus
- **Operating Temperature:** -20°C to +50°C / -4°F to +122°F
- **Storage Temperature:** -20°C to +70°C / -4°F to +158°F
- **Environment:** Outdoor (Dot XL:IP66, IP67 rated; Pixel Distributor: IP66 rated; PSU: IP67 rated)

ELECTRICAL SPECIFICATIONS

- **Operating Voltage:** 15V DC
- **Power Consumption²:** DO.XB.7100000/DO.YB.7100000: 2.5W
DO.XC.7100000/DO.YC.7100000: 3.5W

SYSTEM SPECIFICATIONS

- **Power/Data Interface:** TX CONNECT
- **Control:** DMX or e:pix (DVI capable)
- **Power Supply:** LED Engine 150W 15V Outdoor [PS.OA.0012000]
- **Addressing Options:** Auto-Addressing

1. Diffuser Dome is available upon request. Please consult your regional Traxon office for further details and aid.
2. Measurement per dot.

LED CHARACTERISTICS Because LEDs are semiconductor devices, their performances are subject to inherent variability commonly found in semiconductor industry. To improve consistency in performance across the same product, LED manufacturers "sort" LEDs into bins according to different preset parameters, such as forward driving voltage, illumination, etc. Whereas binning is a sorting function, it is not a correction process. Inherent variability in the manufacturing process results always in different binning distributions according to different production lots. Traxon uses automatically binned LEDs on its products, thereby minimizing output variations within the model range.

As with all electronic devices, LED output degrades over time – a term called lumen depreciation. This also explains why it is nearly impossible to expect photometric performances of two LED products with different service life spans to be the same. The rate of LED degrade is a complicate function of many factors such as operating efficiency, duration of continuous operation, and more significantly, environmental conditions (ambient temperature for example). If allowed working under optimal operating temperature range and with good ventilation, LED devices enjoy long service lives over conventional light sources. When using/installing LED devices, care should be taken to ensure that the devices will operate within the operating conditions specified in respective product literature.



Dot XL-6 RGB
Dot XL-9 RGB

Photometrics

SOURCE SPECIFICATIONS

Source: 6 LEDs packaged in RGB (One Dot XL-6) / 9 LEDs packaged in RGB (One Dot XL-9)

Optics: 120° (clear cover)

Cover Lens: Clear PC

CCT: –

CANDELA DISTRIBUTION

LIGHT OUTPUT

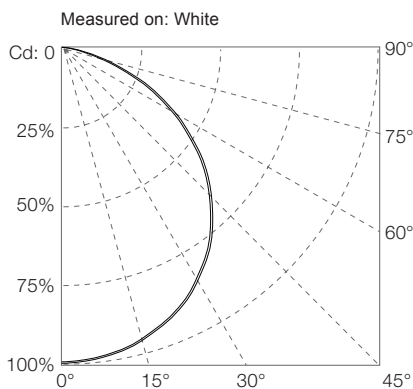

	Color	Luminous Flux (lm)	Candela Distribution at 100%	Efficacy (lm/W)
Dot XL-6	White	42.72	15.4	17.09
	Red	12.09	4.3	4.84
	Green	28.40	10.3	11.36
	Blue	4.34	1.6	1.74
Dot XL-9	White	65.88	23.9	18.82
	Red	19.53	7.1	5.58
	Green	42.81	15.6	12.23
	Blue	6.97	2.6	1.99

ILLUMINANCE AT A DISTANCE

	Dot XL-6			Dot XL-9		
	Center Beam LUX	Beam Width (m)		Center Beam LUX	Beam Width (m)	
		V	H		V	H
1m	15	2.94	2.98	24	2.89	2.96
2m	4	5.87	5.96	6	5.78	5.91
3m	2	8.81	8.94	3	8.67	8.87
4m	1	11.74	11.92	1	11.56	11.83
5m	1	14.68	14.91	1	14.45	14.78

For fo divide by 10.7

For feet multiply by 3.28

Measurements for other optics, IES and LDT files are available for download from the Traxon website

WWW.TRAXONTECHNOLOGIES.COM

©2012 TRAXON TECHNOLOGIES ALL RIGHTS RESERVED. TRAXON™, TX CONNECT™, LUXILED™ ARE TRADEMARKS OF TRAXON TECHNOLOGIES. U.S. PATENTS, E.U. PATENTS, JAPAN PATENTS, OTHER PATENTS PENDING. SPECIFICATIONS ARE SUBJECT TO CHANGE WITHOUT NOTICE.



Dot XL-6 RGB
Dot XL-9 RGB

Photometrics

SOURCE SPECIFICATIONS

Source: 6 LEDs packaged in RGB (One Dot XL-6) / 9 LEDs packaged in RGB (One Dot XL-9)

Optics: 170°

Cover Lens: Diffuser Dome (PC)*

CCT: –

CANDELA DISTRIBUTION

LIGHT OUTPUT

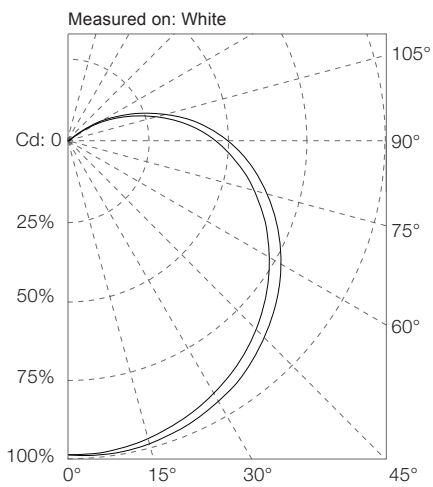

	Color	Luminous Flux (lm)	Candela Distribution at 100%	Efficacy (lm/W)
Dot XL-6	White	28.20	5.1	11.28
	Red	9.73	1.8	3.89
	Green	16.93	6.1	6.77
	Blue	2.95	0.5	1.18

	Color	Luminous Flux (lm)	Candela Distribution at 100%	Efficacy (lm/W)
Dot XL-9	White	43.70	7.9	12.49
	Red	14.92	2.7	4.26
	Green	27.13	4.9	7.75
	Blue	5.08	0.9	1.45

ILLUMINANCE AT A DISTANCE

	Center Beam LUX		Beam Width D	
	Dot XL-6	Dot XL-9	Dot XL-6	Dot XL-9
	1m	5	8	23.98m
2m	1	2	47.95m	48.66m
3m	1	1	71.93m	72.98m
4m	0	0	95.91m	97.31m

For fc divide by 10.7

For feet multiply by 3.28

* Diffuser Dome is available upon request. Please consult your regional Traxon office for further details and aid.

Measurements for other optics, IES and LDT files are available for download from the Traxon website

WWW.TRAXONTECHNOLOGIES.COM

©2012 TRAXON TECHNOLOGIES ALL RIGHTS RESERVED. TRAXON™, TX CONNECT™, LUXILED™ ARE TRADEMARKS OF TRAXON TECHNOLOGIES. U.S. PATENTS, E.U. PATENTS, JAPAN PATENTS, OTHER PATENTS PENDING. SPECIFICATIONS ARE SUBJECT TO CHANGE WITHOUT NOTICE.

TECHNICAL DRAWING

DOT XL

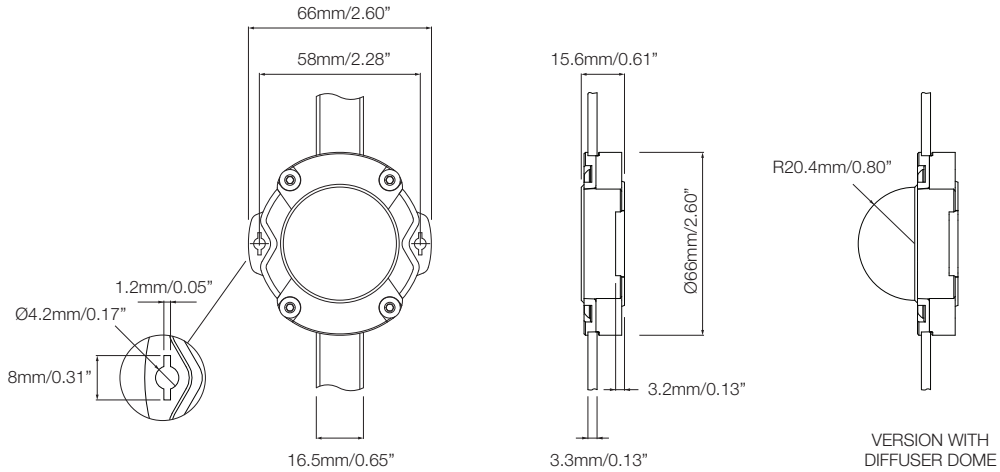

PIXEL DISTRIBUTOR WITH POWER SUPPLY

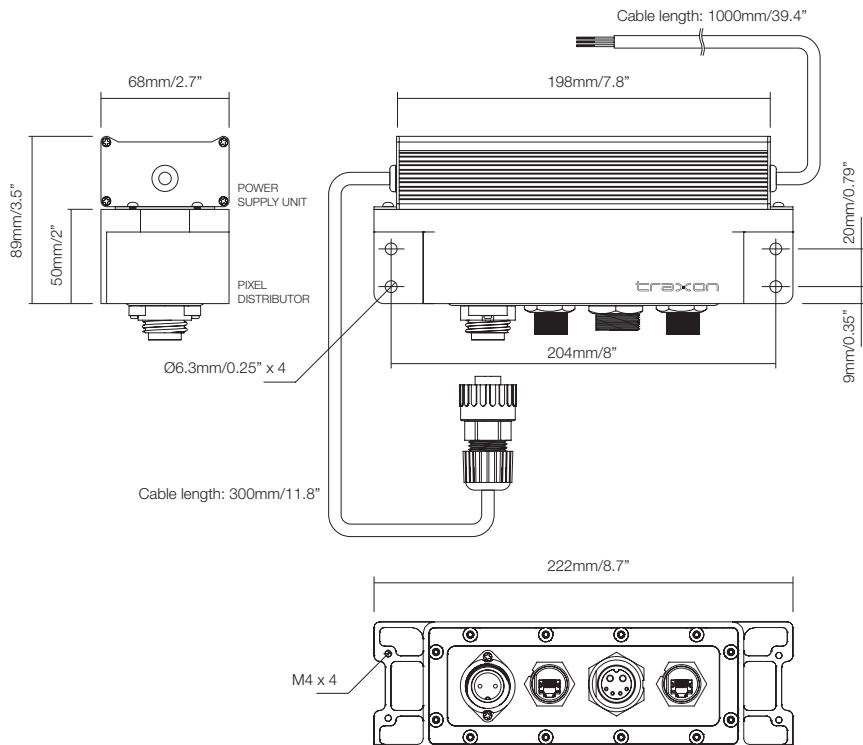

MOUNTING

DOT XL

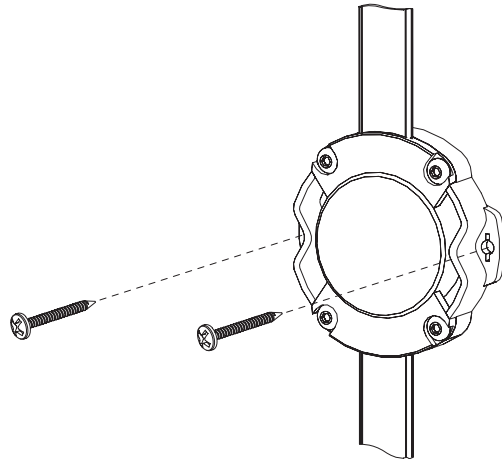

PIXEL DISTRIBUTOR

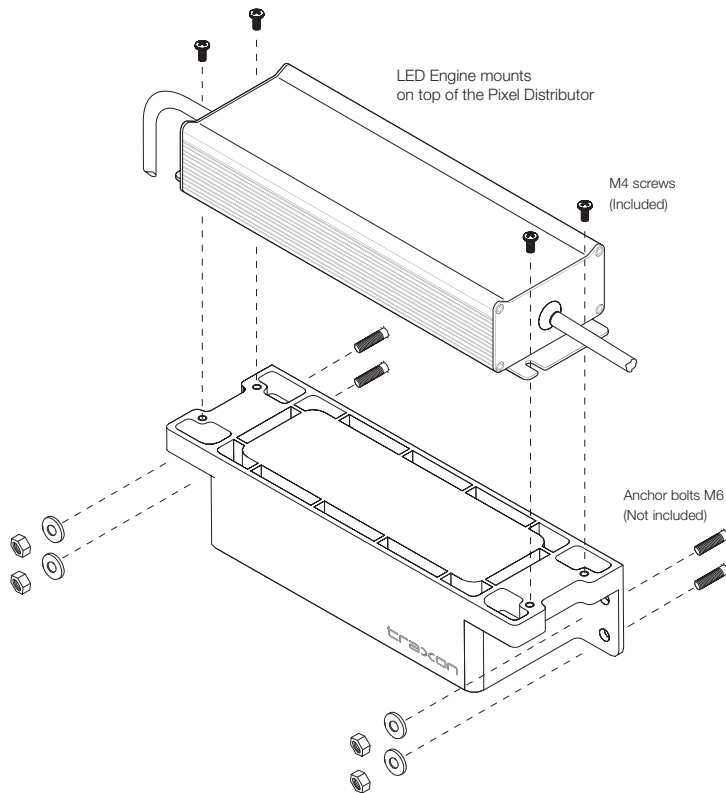

FIELD-CUT END CAP

Terminating the Dot XL cable and sealing with Field-cut End Cap (End Cap not included)

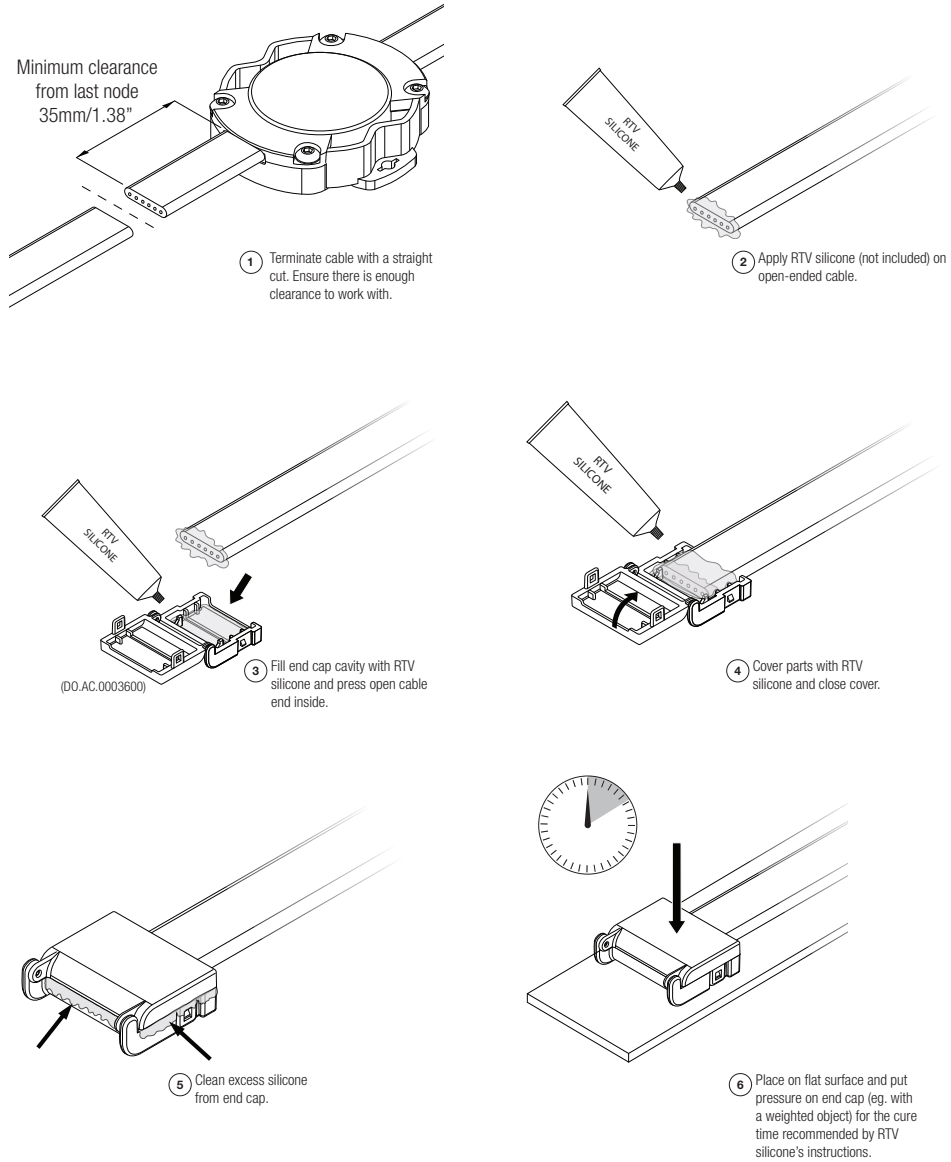

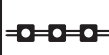

Dot XL-6 RGB
Dot XL-9 RGB

System Diagram

SYSTEM DIAGRAM – BUTLER

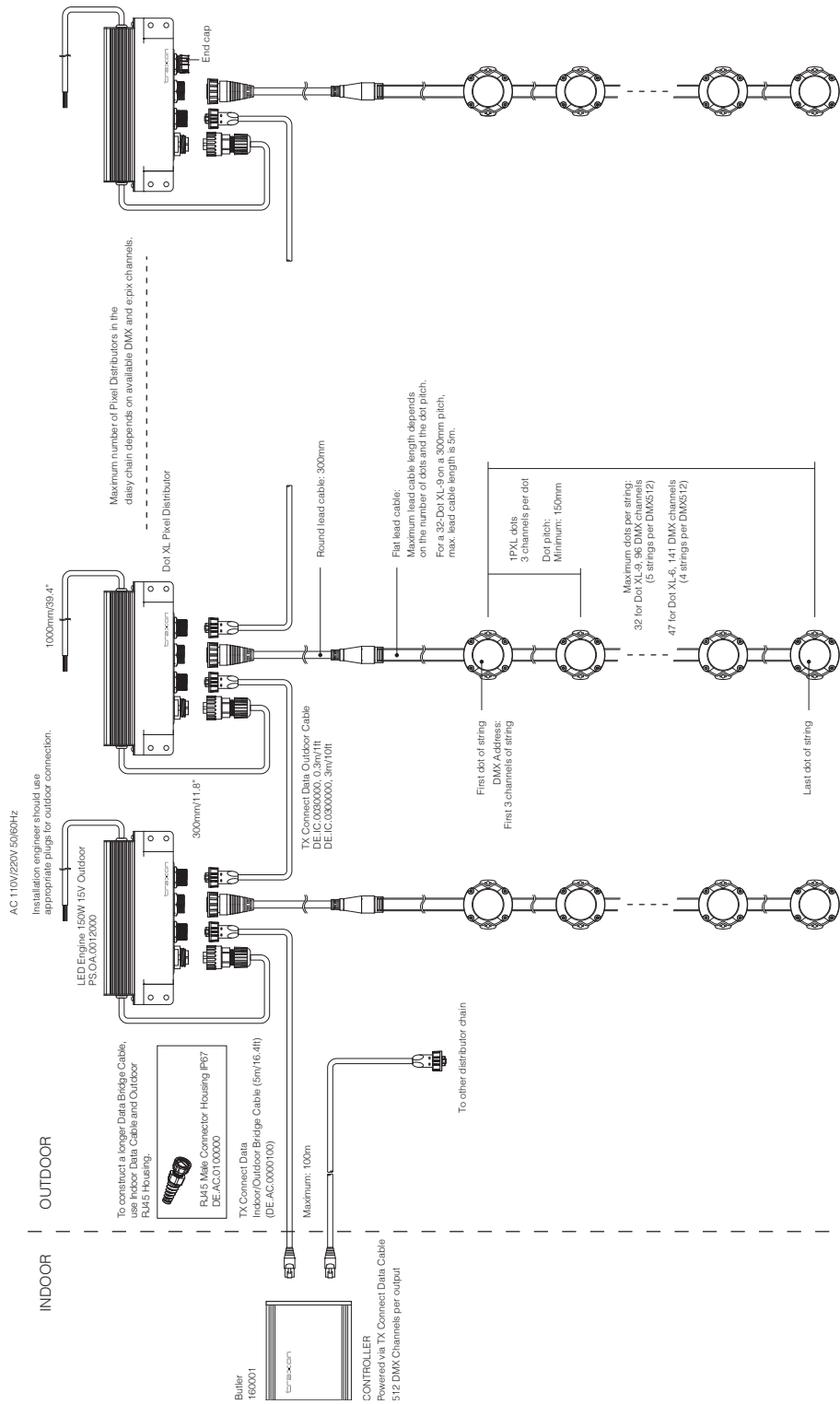



Dot XL-6 RGB
Dot XL-9 RGB

System Diagram

SYSTEM DIAGRAM – VIDEO MICRO CONVERTER

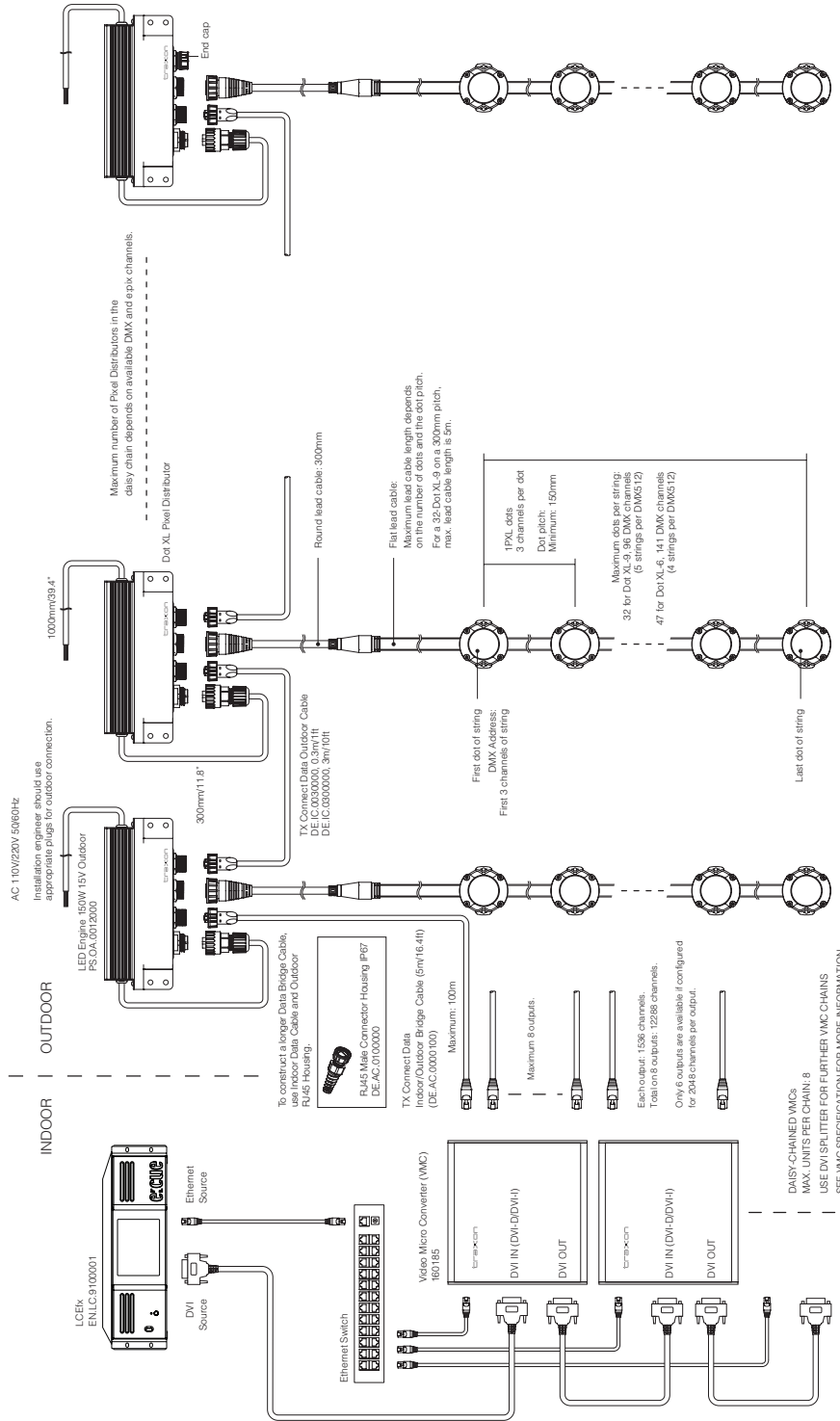



Dot XL-6 RGB
Dot XL-9 RGB

Accessories

STANDARD ACCESSORIES (included in delivery)

Model No.	Description
	1x Pixel Distributor, 4x M4 Screws

OPTIONAL ACCESSORIES

Model No.	Description
DO.AC.0003600	Field-cut End Cap (50pcs)

TX CONTROL

Model No.	Description
160001	Butler
160052	Butler Garage (Optional)
160185	Video Micro Converter (DMX/e:pix)
160194	Video Micro Converter Garage (Optional)

TX CONNECT

Model No.	Description
DE.AC.0000100	TX CONNECT Data Indoor/Outdoor Bridge Cable, 5m/16.4ft
DI.IC.0100000	TX CONNECT Data Cable, 1m/3.28ft
DI.IC.0300000	TX CONNECT Data Cable, 3m/9.84ft
DI.IC.1000000	TX CONNECT Data Cable, 10m/32.8ft
DE.IC.0060000	TX CONNECT Data Outdoor Cable, 0.6m/1.97ft
DE.IC.0300000	TX CONNECT Data Outdoor Cable, 3m/9.84ft
DE.AC.0100000	RJ45 Male Connector Housing IP67

TX POWER

Model No.	Description
PS.OA.0012000	LED Engine 150W 15V Outdoor